



BLUE OX®

Baseplate Installation Instructions

BX2714

2008-09 Kia Optima

(No Foglights)

Installation Instructions

Serial Number

Please read BOTH these Installation Instructions and the General Towing Instructions before attempting to install or operate this equipment.

1. Blue Ox® towing products and accessories are intended to be installed by Blue Ox® Dealers who are familiar with our products and have the equipment and knowledge to do "fit work." When necessary, Blue Ox® Dealers can be found at www.blueox.com or by contacting our Customer Care Department at (402) 385-3051.

Attachment Tab Height: 14"

Attachment Tab Width: 25"

2. Many Blue Ox® Baseplates are designed to use existing holes and hardware to mount the baseplate to the towed vehicle. Even though bolts are there, do not assume they are adequate for baseplate mounting. Always use hardware supplied in the hardware kit or existing hardware specified in the Baseplate Towing Installation Instructions.

Bolt Torque Specifications

Torque in Foot-Pounds for Metric Bolts

Bolt Size	Grade 8.8	Grade 10.9
6MM	6	8
8MM	16	22
10MM	31	40
12MM	54	70
14MM	89	117

Confirm the towability and pre-towing procedures for your vehicle with the owner's manual or contact the vehicle's manufacturer for specific towing procedures.

Bolt Torque Specifications

Torque in Foot-Pounds for Inch Bolts

Bolt Size	Grade 5	Grade 8
1/4"	10	14
5/16"	19	29
3/8"	33	47
7/16"	54	78
1/2"	78	119
5/8"	154	230



If the front of your vehicle looks different than this, call us at (402) 385-3051.

! WARNING

Failure to read and follow these instructions could result in separation of the towed vehicle from the tow bar, causing property damage, loss of towed vehicle, personal injury or death.

BX2714

2008-09 Kia Optima (No Foglights)

Installation Instructions

Parts List

Ref. No.	Qty.	Part #	Description
1	1	61-6634	Weldment, BP, BX2714
2	4	61-5208	Weldment, Nut Plate, 1/4x1x1, 3/8 Bolt w/10" Wire
3	8	201-0368	3/8-16x1 1/4 Hex Head Bolt, Grd. 5
4	4	203-0010	3/8 Lock Washer, ZP
5	4	202-0090	3/8-16 Hex Nyl. Ins. Lock Nut, ZP
6	1	201-0655	6MM-1.0 X 30MM Hex Bolt, Grd8.8,ZP
7	1	203-0008	1/4 Lock Washer, ZP
8	1	203-0001	1/4 Flat Washer, ZP
9	2	201-0979	#12-14 x 1" Self Drilling Screw, ZP
10	2	201-0192	#10-32x1/2" Slot, Round Head Screw
11	2	203-0054	#10 Lock Washer
12	2	202-0047	#10-32 Hex Nut
13	2	101-5822	Adapter, 4 Way Connector
14	2	62-3468	Attachment, Assembly, SF/SB, 1 Hole
	2	290-0437	Cap Plug, Black (Not Shown)
	2	229-0359	Quicklink, 3/8", ZP (Not Shown)
	2	226-0046	Baseplate Safety Cable, 36" Class III (Not Shown)

Tools Required

8MM Socket	Drill
10MM Socket	Phillips Screwdriver
9/16" Socket/Wrench	Hack Saw Blade
5/16" Nut Driver	1 1/4" Hole Saw
Large Vise Grips	13/32" Drill Bit
Reciprocating Saw	Loctite® RED

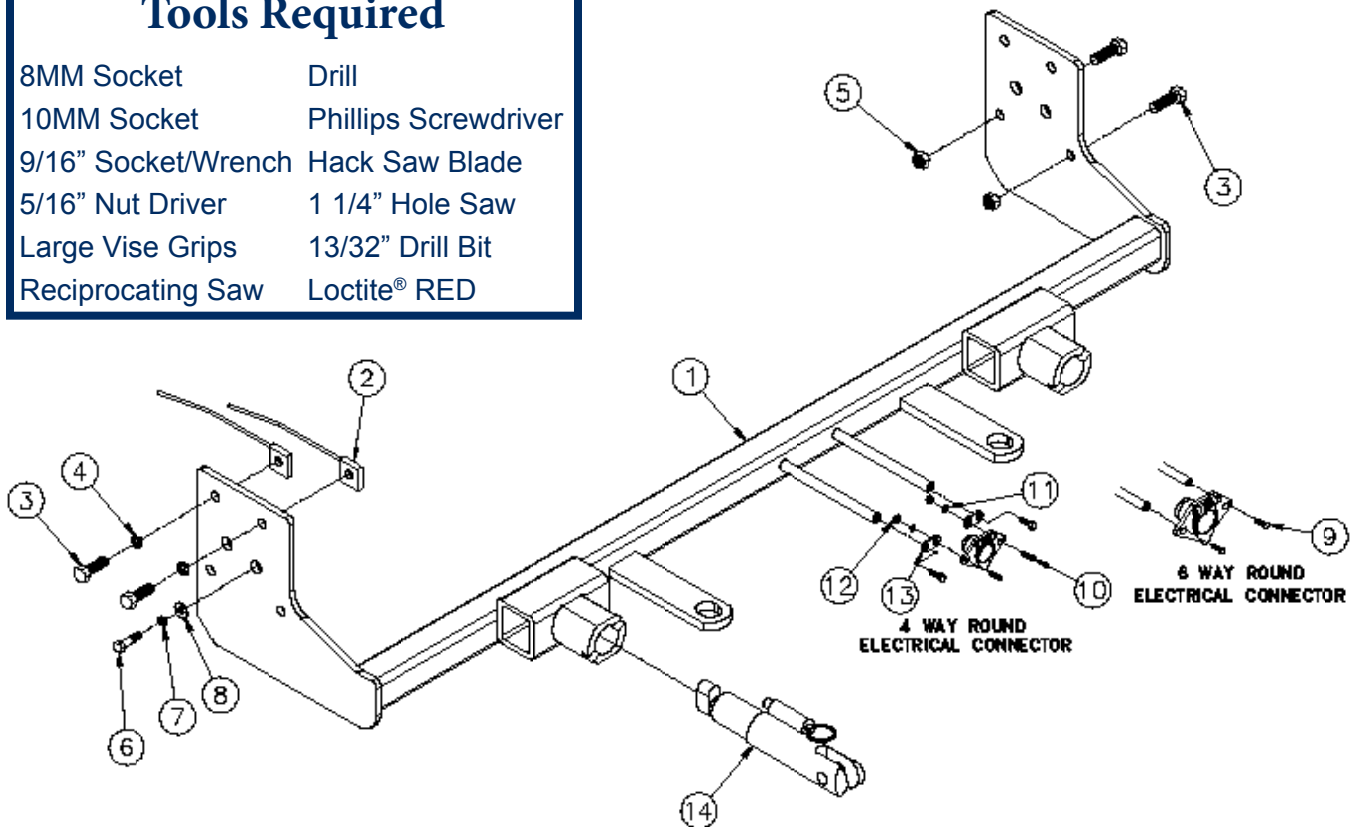

Important:

Use only genuine factory replacement parts on your baseplate. Do **NOT** substitute homemade or non-typical parts. If a bolt is lost or in need of replacement, for your safety and the preservation of your baseplate, be sure to use a replacement bolt of the same grade (In most cases it will be Grade 5, please reference the parts list above). Replacement parts may be ordered through your nearest Blue Ox® Dealer or Distributor. Failing to follow and/or altering these installation instructions in either installation or required equipment will void the manufacturer's warranty. Towing behind a non-motorized vehicle will void the warranty.

BX2714

2008-09 Kia Optima (No Foglights)

Installation Instructions

Vehicle Weight:

Due to the design of the removable tabs, the RangeFinderII and Ambassador tow bars can not be used. Adapters, except the BX8833 and BX88151, can not be used with this baseplate.

Installation Notes: The fascia, belly pan, air baffle and washer reservoir are removed and reinstalled during installation of the baseplate. Drilling is required. Trimming of the bumper and fascia is required.

The dimensional variations between otherwise identical vehicles can be considerable. While the baseplate was designed for easy installation, it may be necessary to tailor the baseplate slightly to compensate for auto manufacturer's tolerances. These minor adjustments may include filing a hole slightly, bending electrical rods or bending end plates.

The BX8869 Bulb and 'Socket Wiring Kit is recommended for this vehicle.



Handling of some cosmetic parts when installing this product may require the use of protective covers, rags, specialty tools, etc. to prevent damage.

Installation Instructions:



1. Using a 10MM socket, remove two metric bolts from the air intake housing (gray arrows). Using a Phillips screwdriver, remove three plastic Phillips pushpins located near the air intake housing (white arrows, continued in step 2). Set bolts and pushpins aside to be reinstalled later.

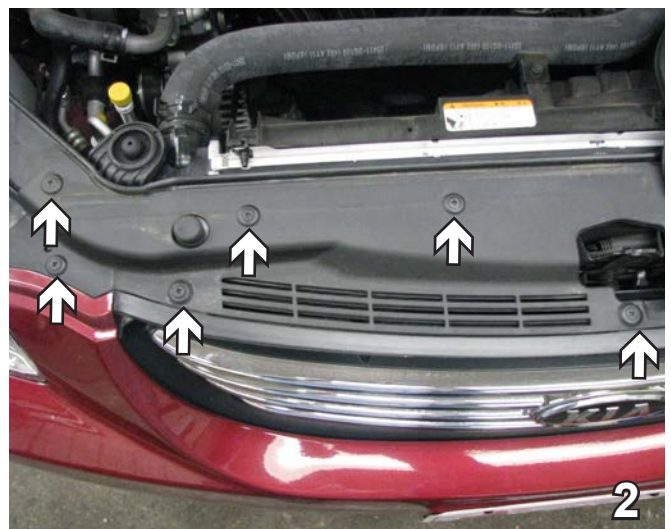

2. Using a Phillips screwdriver, continue removing six plastic Phillips pushpins located near the air intake housing. Set pushpins aside to be reinstalled later.

BX2714

2008-09 Kia Optima (No Foglights)

Installation Instructions



3. Using a Phillips screwdriver or an 8MM socket, remove one plastic Phillips pushpin just forward of the front tire on the wheel well. Do this to both sides of the vehicle. Set pushpin aside to be reinstalled later.



4. Using a Phillips screwdriver, remove four plastic Phillips pushpins from just forward of the front tire along the bottom edge of fascia. Do this to both sides of the vehicle. The fascia is then ready to be removed from the vehicle by pulling fascia ends out to the side to release and then pulling it forward. Set fascia and pushpins aside carefully to be reinstalled later. Unplug the light.



5. In order to remove the belly pan, remove two plastic Phillips pushpins located under the radiator. Set pushpins aside to be reinstalled later.



6. Remove one push pin in the center of the belly pan (gray arrow). Using a 10MM socket, remove six metric bolts around the edge. Set belly pan, bolts and push pin aside to be reinstalled later.

BX2714
2008-09 Kia Optima (No Foglights)
Installation Instructions



7. On the driver's side, remove the air baffle. Use a 10MM socket to remove the three bolts holding it on, one on each side and one above. Set the air baffle and bolts aside to be reinstalled later.



8. On the passenger side, using a 10MM socket remove the two bolts on the left side. Loosen the bolt on the right side so the washer reservoir can be removed. Disconnect the wires and plug the hoses. Set the washer reservoir and bolts aside to be reinstalled later.
9. On the passenger side, remove the screw from behind the washer reservoir. Use a Phillips screwdriver or a vise grips. Set the screw aside to be reinstalled later.

2008-09 Kia Optima (No Foglights)

Installation Instructions

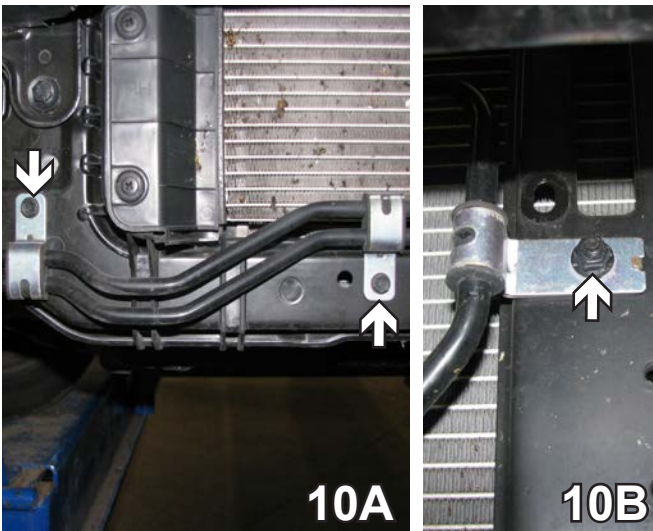

10. On the passenger side, using a 10MM socket remove the three bolts supporting the coolant line up. Let the line hang down during the cutting. It will be reattached later.

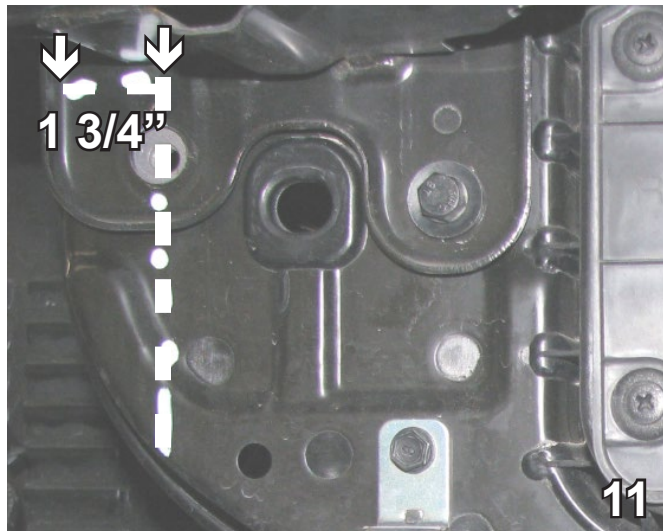

11. Mark over 1 3/4" from the end of the bumper. Using a reciprocating saw, trim over and straight down. The passenger side is shown. Do this to both sides of the vehicle.

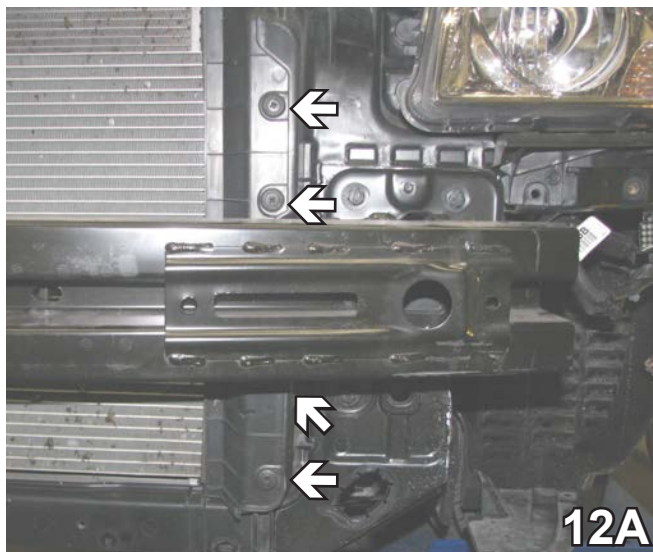

12. Remove the plastic guard by removing the two push pins above and two push pins below the bumper. Do this to both sides of the vehicle.



13. Using a reciprocating saw, cut horizontally flush with the bottom of the bumper and in 1" all the way down. Do this on both sides of the vehicle. Be careful not to cut the condenser or the line.

BX2714

2008-09 Kia Optima (No Foglights)

Installation Instructions



14. Align fascia to its original position, cut the center rib out as needed on the far end of the fascia grille using a hack saw blade. This will allow for the attachment tab receiver to come through. Do this on both sides of the vehicle.



15. Underneath the frame, using a 1 1/4" hole saw, drill a hole in the bottom of the frame for the nut plates. Do this to both sides of the vehicle.

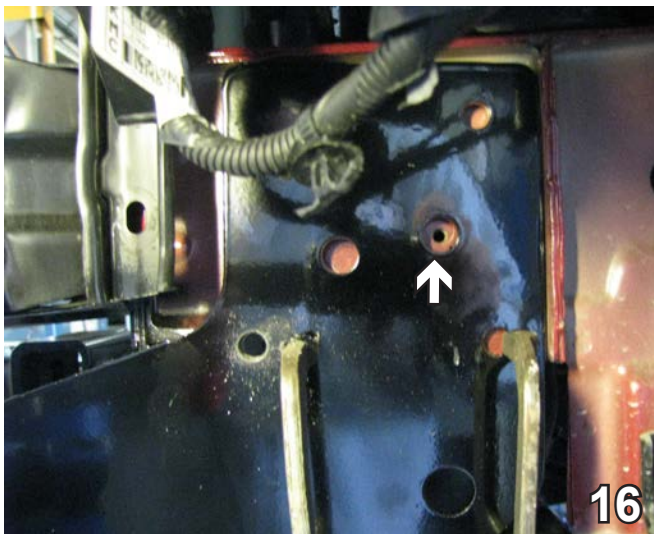

16. Hold the baseplate up, line it up with the existing hole and clamp. Using the 13/32" drill bit, drill out the hole. Insert a 3/8-16 x 1 1/4" hex bolt with Loctite and fasten to a 3/8-16 nylon insert hex nut. Do this to both sides of the vehicle.



17. Using the baseplate as a template, drill the rest of the holes using the 13/32" drill bit. Insert 3/8-16 x 1 1/4" hex bolts with Loctite in all the holes. In the top two holes (white arrows), attach 3/8" lock washers and tighten to 3/8" nut plates inserted into the frame. In the bottom two holes (gray arrows), tighten to 3/8-16 nylon insert hex nuts. Do this to both sides of the vehicle.

BE SURE TO USE LOCTITE® RED ON ALL BOLTS BEFORE TIGHTENING. TIGHTEN ALL BOLTS ACCORDING TO THE TORQUE CHART ON THE FRONT PAGE OF THESE INSTRUCTIONS OR ON PAGE 3 OF THE BASEPLATE TOWING GENERAL INSTRUCTIONS.

When using power drills be aware of the dangers of torque and drill bit length.

BX2714

2008-09 Kia Optima (No Foglights)

Installation Instructions



18. Attach the permanent baseplate safety cables to the provided convenience link on the baseplate (see grey arrow). The photo above shows the recommended installation of the cables to frame of vehicle (see white arrow). Additional options may interfere with suggested mounting; in this case secure the cables to a solid piece of the frame as described in the instructions included with the permanent baseplate safety cables. Be sure the safety cables do not rub against any hoses or moving parts. Do this to both sides of the vehicle.



19. On the driver's side, put the air baffle back on using existing bolts.

Be sure that **ALL** electrical connections are plugged in properly and functioning **BEFORE** installing the fascia.

21. Reinstall the belly pan and the fascia. Be sure to install all bolts and push pins.

DEALER or INSTALLER:
Be certain the user receives the instruction sheets for their products.



20. On the passenger side, reinstall the washer reservoir with two existing bolts. On the right side, use a 6MM hex bolt with 1/4" flat and lock washers that are provided in the bolt bag.

Install the tow bar and safety cables according to the instructions provided in their packages. When demonstrating this to the customer, be sure to include all the contents and packages.

Do **NOT** substitute other devices if the tow bar pins and clips are misplaced.

BX2714

2008-09 Kia Optima (No Foglights)

Installation Instructions



Shown without removable tabs installed.



Shown with removable tabs installed.

If the baseplate is in an accident, it must be replaced. DO NOT use it again! An accident can cause unseen damage and using it again could result in more damage or serious injury. DO NOT use the baseplate if it is damaged or missing parts.

CUSTOMER SERVICE COMMITMENT

Blue Ox is committed to providing you with exceptional customer care throughout your lifetime with our products. Our team is here to assist you with any questions you may have regarding the performance of your product. Simply call (402) 385-3051 and you can speak with our customer care team.

Additionally, please visit our website to see which rallies our Destination America team will be attending. For a nominal fee, our service technician will service your towing system to ensure it's in proper working condition. Also as a commitment to our customers, should you visit our factory you can stay at our full service Blue Ox campground at no charge along with enjoying a factory tour.

Again thank you for being our customer and for the confidence you have shown in the performance of our products. It is because of customers like you we enjoy the success we have today.



© 2009, 10 Blue Ox
One Mill Road, Industrial Park
Pender, Nebraska 68047
Phone: (402) 385-3051 • Fax: (402) 385-3360
www.blueox.com

General Information

1. Ensure that your product(s) are registered online at www.blueox.com. It is crucial to register your product(s) so that you may be alerted of product offerings, updates, upgrades, maintenance and safety bulletins, and/or recalls.
2. **It is the owner's responsibility to inspect all towing equipment for cracked welds, missing or worn parts and loose bolts before each towing trip.** Be sure to use Loctite® Red on all bolts and tighten to the recommended specifications.
3. **It is the owner's responsibility to hook up all towing equipment per manufacturer's instructions/recommendations.**
4. Remove the attachment tabs when not in use (if applicable).

Notice To Baseplate Installer

1. It is YOUR responsibility to watch for:

- Oil cooler and air conditioner lines
- Electrical wires and hoses
- Missing parts or attaching points on the frame

** If the baseplate is improperly installed and is against a wire or hose, it could cause fluid leaks or electrical shorts some time after the actual baseplate installation.

Permanent Baseplate Safety Cable Installation

Permanent baseplate safety cables are strongly recommended when towing a vehicle with a tow bar. The principle function of the permanent baseplate safety cables is to prevent the towed vehicle from breaking loose in the event the connection between the frame of the towed vehicle and the baseplate fails or becomes disconnected. The cables must be connected from the baseplate to the frame rail or cross member of the vehicle's frame. The illustrations below show the possible arrangements recommended by Blue Ox®. Each permanent baseplate safety cable must have an adequate weight rating for the towing system. The weight rating of the two (2) cables together will not qualify.

Do not mount the permanent baseplate safety cables against wires, hoses or brake lines.

These permanent baseplate safety cables should remain installed as long as the baseplate is installed on the vehicle. Permanent baseplate safety cables are to be used in conjunction with, and NOT a replacement for legally required safety cables attaching the towed vehicle to the towing vehicle.

OPTION #1

Permanent Baseplate Safety Cables to Cross Member or Frame of Towed Vehicle.

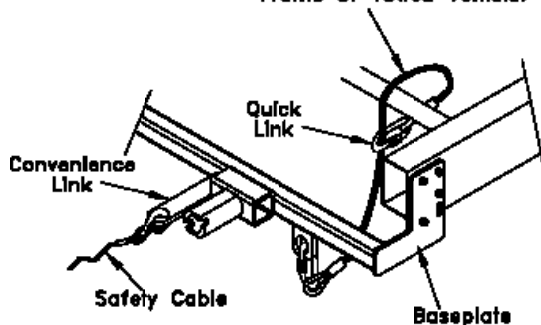

OPTION #2

Permanent Baseplate Safety Cables to Cross Member or Frame of Towed Vehicle.

