



Strong As An Ox™

BX2707 Installation Instructions 2003 Kia Sorento LX

Serial No.

The headlight assembly, front fascia, horn bracket and windshield washer reservoir are removed for baseplate installation. Drilling is required. Trimming of air dam on metal bumper is required. The BX8869 is available for the vehicle. Attachment Tabs are 24 inches center to center and a height of 13 1/2 inches.



1. Remove the two Phillips push pins from black plastic on both sides. Remove six Phillips push pins on plastic covering metal bumper.



2. Remove three metric bolts from headlight assembly with the 10MM socket, pull forward, unplug electrical and set aside, both sides.



3. Just under headlight assembly are Phillips push pins to remove, both sides. Lift vertical black plastic, remove plastic over the top of metal bumper and set aside.



4. Just under plastic, in step three, are six Phillips push pins to remove.



5. Remove one metric bolt just behind headlight assembly using the 7MM socket, both sides.



6. Remove two Phillips screws from the bottom middle of fascia.



Strong As An Ox™



7. Just forward of front tire are two phillips push pins to remove, both sides.



8. Using the 10MM socket, remove two metric bolts in fascia opening.



9. Just forward and above front tire, on fascia's corner, is one phillips screw to remove, both sides. Pull fascia corners down, then pull fascia forward and set aside.



10. Remove six metric bolts on forward belly pan using the 12MM socket and set aside.



11. On the bottom of metal bumper are two brackets for the fascia, bend brackets forward. This will open up area for baseplate installation.



12. Align lower hole on baseplate ends, with large hole just behind tow hook bracket and secure baseplate to tow hook bracket with vise grips. Bend the fascia brackets, in step 11, back to their original position.



Strong As An Ox™



13. While maintaining a level position with the attachment tabs, drill the two top holes using the baseplate as a template, using the 13/32" drill bit, both sides. Insert the nut plate into the opening on the front of the metal bumper to align with drilled holes in frame. Slide spacer plate between frame and baseplate's upper hole from the top, both sides. Then install and tighten the 3/8" lock washer and bolt, both sides. **Be sure and use loctite on all bolts before tightening. Tighten all bolts according to torque chart on the General Instruction Sheet.**



14. Insert the 1/2 x 4" bolt through baseplate's lower hole, through tow hook bracket and insert spacer tube into opening around 1/2" bolt. Install 1/2" flat washer, 1/2" lock washers, 1/2" hex nut on both sides and tighten. **Be sure and use loctite on all bolts before tightening. Tighten all bolts according to torque chart on the General Instruction Sheet.**



15. While holding belly pan just below original position, mark areas to be cut out, see photos above. If measuring from bolt holes, out 1" should be the approximate location to start cutting down 4" and to the side 5 3/4" on both sides using the hack saw. It will be necessary to cut an opening between the two holes on the front of the belly pan. Reinstall belly pan.

16. Reinstall fascia components and head light assemblies. **Be sure all electrical connections are plugged in properly.**

17. The dimensional variations between otherwise identical cars can be considerable. While the location and size of the holes in the baseplate were designed to allow for easy installation, it may be necessary to file a hole slightly to allow a bolt to clear.

18. Install the tow bar and safety cables according to the instructions included in their packages.

19. Do **not** substitute other devices if the tow bar pin and clip are lost.

20. **DEALER OR INSTALLER: BE CERTAIN THE USER RECEIVES THE INSTRUCTION SHEET.**



Tools Required

10MM Socket	13/32" Drill Bit	9/16" Socket
12MM Socket	Loctite	3/4" Socket
Phillips Screw Driver	Reciprocating Saw	

Parts List

Ref. No.	Qty.	Part No.	Description
1	1	61-5892	Weldment, Base Plate, BX2707
2	2	102-6426	Spacer Plate, BX2707
3	4	61-5208	3/8" Nut Plate, with Wire
4	2	107-2580	Spacer Tube, BX2707
5	4	201-0440	3/8-16 x 1 1/2 Bolt, Grd. 5, ZP
6	4	203-0010	3/8 Lock Washer, ZP
7	2	201-0581	1/2-13 x 4 Bolt, Grd. 5, ZP
8	2	203-0005	1/2 Flat Washer, ZP
9	2	203-0012	1/2 Lock Washer, ZP
10	2	202-0005	1/2-13 Hex Nut, ZP
11	2	201-0979	#12-14 x 1" Self Drilling Screw, ZP
12	2	201-0192	#10-32 x 1/2 Slot, Rd. Hd. Screw
13	2	203-0054	#10 Lock Washer
14	2	202-0047	#10-32 Hex Nut
15	2	101-5822	Adapter, 4 Way Connector



Location for the Bx8869 on driver's side tail light assembly.

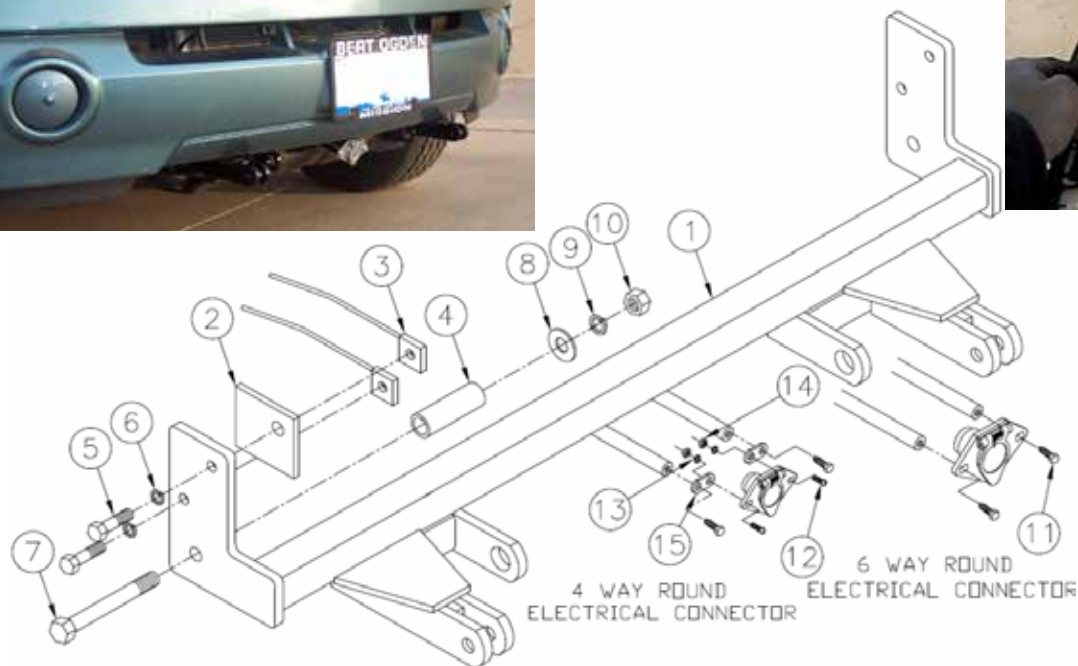

IMPORTANT: Use only genuine factory replacement parts on your Base Plate. Do not substitute homemade or nontypical parts. If a bolt is lost or in need of replacement, for your safety and the preservation of your Base Plate, be sure to use a replacement bolt of the same grade (Usually Grade 5, refer to parts list). Repair parts may be ordered through your nearest **Blue Ox** dealer or distributor.

General Information

1. Ensure that your product(s) are registered online at www.blueox.com. It is crucial to register your product(s) so that you may be alerted of product offerings, updates, upgrades, maintenance and safety bulletins, and/or recalls.
2. **It is the owner's responsibility to inspect all towing equipment for cracked welds, missing or worn parts and loose bolts before each towing trip.** Be sure to use Loctite® Red on all bolts and tighten to the recommended specifications.
3. **It is the owner's responsibility to hook up all towing equipment per manufacturer's instructions/recommendations.**
4. Remove the attachment tabs when not in use (if applicable).

Notice To Baseplate Installer

1. It is YOUR responsibility to watch for:

- Oil cooler and air conditioner lines
- Electrical wires and hoses
- Missing parts or attaching points on the frame

** If the baseplate is improperly installed and is against a wire or hose, it could cause fluid leaks or electrical shorts some time after the actual baseplate installation.

Permanent Baseplate Safety Cable Installation

Permanent baseplate safety cables are strongly recommended when towing a vehicle with a tow bar. The principle function of the permanent baseplate safety cables is to prevent the towed vehicle from breaking loose in the event the connection between the frame of the towed vehicle and the baseplate fails or becomes disconnected. The cables must be connected from the baseplate to the frame rail or cross member of the vehicle's frame. The illustrations below show the possible arrangements recommended by Blue Ox®. Each permanent baseplate safety cable must have an adequate weight rating for the towing system. The weight rating of the two (2) cables together will not qualify.

Do not mount the permanent baseplate safety cables against wires, hoses or brake lines.

These permanent baseplate safety cables should remain installed as long as the baseplate is installed on the vehicle. Permanent baseplate safety cables are to be used in conjunction with, and NOT a replacement for legally required safety cables attaching the towed vehicle to the towing vehicle.

OPTION #1

Permanent Baseplate Safety Cables to Cross Member or Frame of Towed Vehicle.

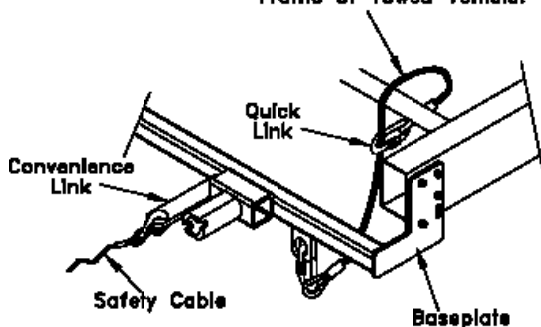

OPTION #2

Permanent Baseplate Safety Cables to Cross Member or Frame of Towed Vehicle.

