

Please read BOTH these Installation Instructions and the General Towing Instructions before attempting to install or operate this equipment.

- Blue Ox® towing products and accessories are intended to be installed by Blue Ox® Dealers who are familiar with our products and have the equipment and knowledge to do “fit work.” When necessary, Blue Ox® Dealers can be found at www.blueox.com or by contacting our Customer Care Department at (402) 385-3051.
- Many Blue Ox® Baseplates are designed to use existing holes and hardware to mount the baseplate to the towed vehicle. Even though bolts are there, do not assume they are adequate for baseplate mounting. Always use hardware supplied in the hardware kit or existing hardware specified in the Baseplate Towing Installation Instructions.

Attachment Tab Height: 14”

Attachment Tab Width: 21”

Bolt Torque Specifications
Torque in Foot-Pounds for Metric Bolts

| Bolt Size | Grade 8.8 | Grade 10.9 |
|-----------|-----------|------------|
| 6MM | 6 | 8 |
| 8MM | 16 | 22 |
| 10MM | 31 | 40 |
| 12MM | 54 | 70 |
| 14MM | 89 | 117 |

Confirm the towability and pre-towing procedures for your vehicle with the owner’s manual or contact the vehicle’s manufacturer for specific towing procedures.

Bolt Torque Specifications
Torque in Foot-Pounds for Inch Bolts

| Bolt Size | Grade 5 | Grade 8 |
|-----------|---------|---------|
| 1/4” | 10 | 14 |
| 5/16” | 19 | 29 |
| 3/8” | 33 | 47 |
| 7/16” | 54 | 78 |
| 1/2” | 78 | 119 |
| 5/8” | 154 | 230 |



If the front of your vehicle looks different than this, call us at (402) 385-3051.

 WARNING

Failure to read and follow these instructions could result in separation of the towed vehicle from the tow bar, causing property damage, loss of towed vehicle, personal injury or death.

BX1840

2007-12 Nissan Sentra

Installation Instructions

| ITEM NO. | PART NUMBER | DESCRIPTION | QTY. |
|----------|-------------|---|------|
| 1 | 61-6379 | WLDMT. BP. BX1840 | 1 |
| 2 | 61-6395 | WLDMT. PS. BX1840 | 1 |
| 3 | 61-5208 | WLD, NUT PLATE, 1/4 X 1 X 1 3/8-16(w/ 1/4" WIRE | 6 |
| 4 | 62-3469 | ATTACH ASSY. REM. S-7/B. 1 HOLE | 2 |
| 5 | 101-7078 | PLATE, END. DS. BX1840 | 1 |
| 6 | 201-0051 | 1/2-13 X 1 1/2" HEX BOLT, GRD. 5, ZP | 4 |
| 7 | 203-0012 | 1/2 LOCK WASHER, ZP | 4 |
| 8 | 202-0005 | 1/2-13 HEX NUT, ZP | 2 |
| 9 | 201-0444 | 3/8-16 X 2 HEX BOLT GRADE 5 ZP | 6 |
| 10 | 201-0368 | 3/8-16 X 1 1/4 HEX HEAD BOLT, GRD. 5 | 2 |
| 11 | 203-0010 | 3/8" LOCK WASHER, ZP | 8 |
| 12 | 202-0003 | 3/8-16 HEX NUT, ZP | 2 |
| 13 | 101-5822 | ADAPTER, 4 WAY CONNECTOR | 2 |
| 14 | 202-0047 | #10-32 HEX NUT | 2 |
| 15 | 203-0054 | #10 LOCK WASHER | 2 |
| 16 | 201-0979 | #12-14 x 1" SELF DRILLING SCREW, ZP | 2 |
| 17 | 201-0192 | #10-32-1/2" SLOT, ROUND HEAD SCREW | 2 |
| 18 | 102-7250 | BREAKAWAY BRKT, BX1840 | 1 |
| 19 | 201-0378 | 8MM-1.25 X 25 MM HEX BOLT, GRD 8.8, ZP | 1 |
| 20 | 201-0050 | 1/4-20 X 3/4 HEX BOLT, GRD. 5, ZP | 1 |
| 21 | 202-0102 | 1/4-20 HEX NYL. NUT, ZP | 1 |
| 22 | 203-0102 | 8MM LOCK WASHER, ZP | 1 |

| Parts Not Pictured: | | |
|---------------------|----------|-------------------------|
| Qty. | Part # | Description |
| 2 | 226-0046 | Baseplate Safety Cables |
| 2 | 229-0359 | Quicklink, 3/8, ZP |
| 2 | 290-0437 | Cap Plug, Black |

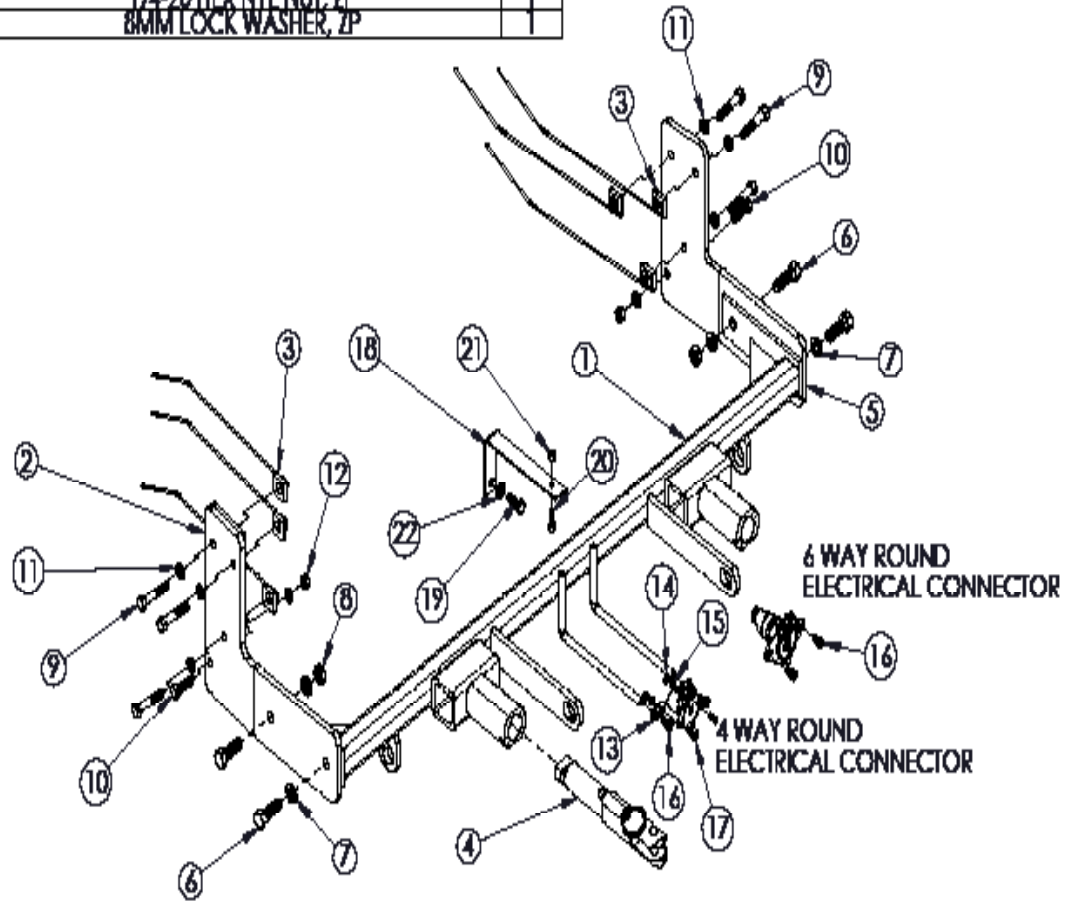

Important:

Use only genuine factory replacement parts on your baseplate. Do NOT substitute homemade or non-typical parts. If a bolt is lost or in need of replacement, for your safety and the preservation of your baseplate, be sure to use a replacement bolt of the same grade (In most cases it will be Grade 5, please reference the parts list above). Replacement parts may be ordered through your nearest Blue Ox® Dealer or Distributor. Failing to follow and/or altering these installation instructions in either installation or required equipment will void the manufacturer's warranty.

BX1840

2007-12 Nissan Sentra

Installation Instructions

Vehicle Weight: Motorhome mount tow bars are recommended for use with this baseplate. Due to the design of the removable tabs, the RangeFinderII and Ambassador tow bars can not be used. Adapters, except the BX8833 and BX88151, can not be used with this baseplate.

Installation Notes: The fascia, metal bumper, washer reservoir and air baffle are removed and reinstalled during installation of the baseplate. Drilling is required. Trimming of the fascia is required.

The dimensional variations between otherwise identical vehicles can be considerable. While the baseplate was designed for easy installation, it may be necessary to tailor the baseplate slightly to compensate for auto manufacturer's tolerances. These minor adjustments may include filing a hole slightly, bending electrical rods or bending end plates.

The BX8869 Bulb and Socket Wiring Kit is recommended for this vehicle.



Possible location for the Bulb and Socket Wiring Kit (BX8869).

Installation Instructions:



1. Using a Phillips screwdriver, remove two bolts located on top of the grille. Do this to both sides. Set bolts aside to be reinstalled later.



2. On bottom edge by tire, there are three Phillips screws to remove on both sides. Remove screws and set aside for reinstallation later.

Do not use the towed vehicle for storing luggage, equipment, etc. This may cause you to exceed the towing capacity of the tow bar, baseplate, and its accessories.

Handling of some cosmetic parts when installing this product may require the use of protective covers, rags, specialty tools, etc. to prevent damage.

BX1840

2007-12 Nissan Sentra

Installation Instructions



3. Using a Phillips screwdriver, remove five push pins from under the fascia. Set aside for reinstallation later.



4. Another push pin is located at the forward of the front tire on the wheel well. Remove with a Phillips screwdriver. Do this to both sides and set push pins aside to reinstall later.



5. Using a 10MM socket, remove bolt from behind plastic of front wheel well. Do this to both sides and set aside bolts to be reinstalled later.



6. Pull fascia forward, there are two pins connecting the air baffle to the frame. There is also a clip (gray arrow) holding a wire for an extra fog light. Pull air baffle loose and unclip wire to remove. Set aside for reinstallation later.



7. Using a 10MM socket, remove two metric bolts holding the washer reservoir (7A), and remove one metric bolt holding the spigot. Set bolts aside for reinstallation later.

BX1840

2007-12 Nissan Sentra

Installation Instructions

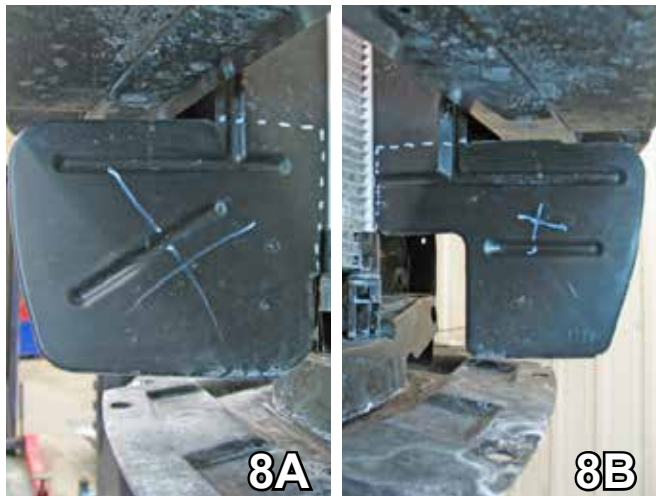

8. You will need to trim the plastic piece located under the metal bumper so it's flush with the bottom of the bumper. The whole piece needs to be removed and discarded. The passenger side (8A) looks different than the drivers side (8B), but needs to be cut. Do this to both sides. These will not be reinstalled.

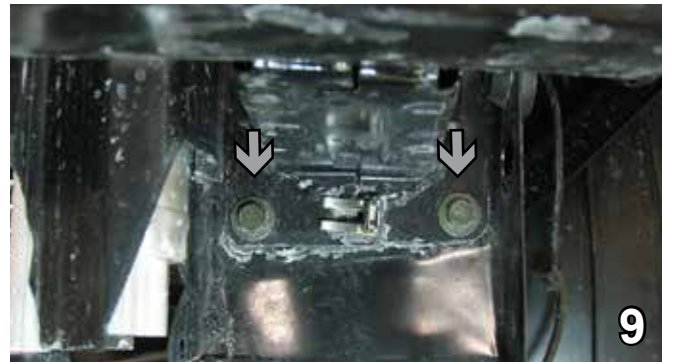
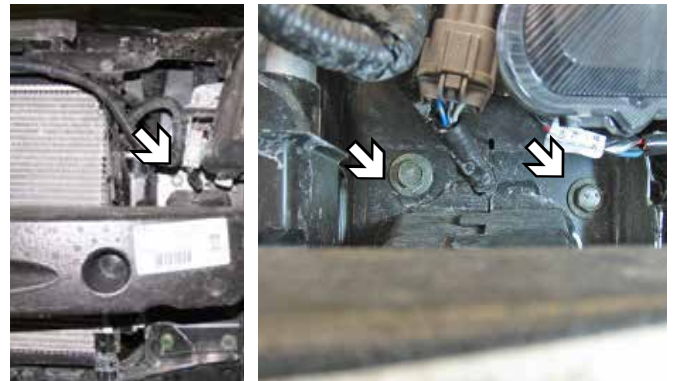

9. You will need to remove the bumper to trim. To do so, take a 13MM socket and remove two 13MM bolts from the top (white arrows) and bottom (gray arrows). Do this to both sides.



10. Measuring 4 1/4" from the bottom of where the two pieces meet, mark cutting lines behind the piece as well - this will remove the bolt and nut. Do this to both sides. Cut both sides using a reciprocating saw and discard. Temporarily bolt metal bumper in place and mark the area that was cut out on the frame end on the back side of the bumper. Do this to both sides. Remove the metal bumper and cut areas from the bumper, set aside to install later.



11. After trimming, drill a 1 1/4" hole on the end of the frame rail to get access on the side of the frame rails. Do this to both sides.

Using a good quality paint, spray cut edges of frame to prevent rusting.

BX1840

2007-12 Nissan Sentra

Installation Instructions

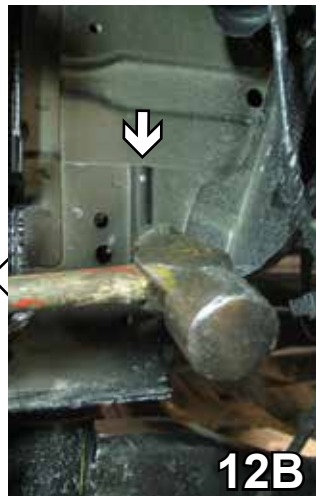
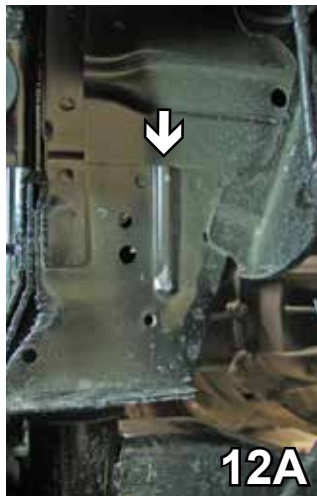

12. Located on the drivers side is a ridge that must be flattened. Using a hammer, flatten the ridge as much as possible in order for the end plate to fit snugly.

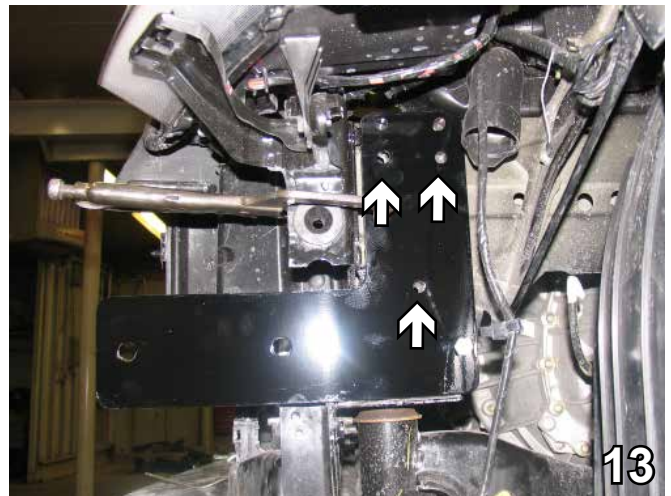

13. Slide end plate in place with vise grips. Keep it in place while it is flush with bottom of lip. Move it forward until it hits the nut. Drill lower back hole and bolt with 3/8-16 hex nut and 3/8 lock washer. Drill top two holes and place 3/8-16 x 2" hex bolt and 3/8 lock washer. The 1/4 x 1 x 1 3/8" nut plate for each of the top holes will be placed from the front on passenger side. Finally, drill middle hole and place 1/2-13 hex nut and 1/2 lock washer inside. This holes nut plate will need to be placed from the back side on drivers side only. Do on both sides.

BE SURE TO USE LOCTITE® RED ON ALL BOLTS BEFORE TIGHTENING. TIGHTEN ALL BOLTS ACCORDING TO THE TORQUE CHART ON THE FRONT PAGE OF THESE INSTRUCTIONS OR ON PAGE 3 OF THE BASEPLATE TOWING GENERAL INSTRUCTIONS.

When using power drills be aware of the dangers of torque and drill bit length.



14. Install the cross member by aligning the holes, and bolting the first hole with a 1/2-13 x 1 1/2 hex bolt with matching lock washer. Insert 3/8-16 hex nut and matching lock washer into the second hole with nut plate. Do this to both sides. Reinstall the metal bumper.



15. Reattach air baffle and washer reservoir with the same pins and bolts.

BX1840
2007-12 Nissan Sentra
Installation Instructions

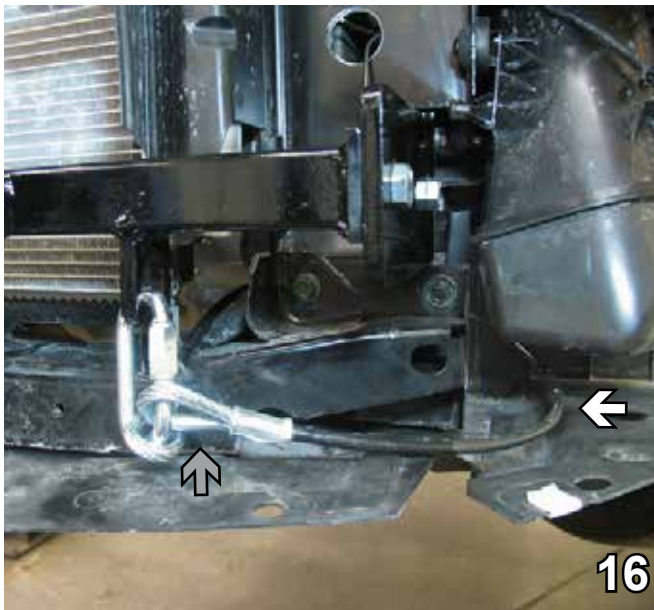

16. Attach the permanent baseplate safety cables to the provided convenience link on the baseplate (gray arrow). The photo above shows the recommended installation of the cables to frame of vehicle (white arrow). Additional options may interfere with suggested mounting; in this case secure the cables to a solid piece of the frame as described in the instructions included with the permanent baseplate safety cables. Be sure the safety cables do not rub against any hoses or moving parts. Do this to both sides of the vehicle.



17. Align the fascia to its original position, remove area around attachment tab receiver to allow it to come through the fascia. Do this to both sides of the vehicle.

Install the tow bar and safety cables according to the instructions provided in their packages. When demonstrating this to the customer, be sure to include all the contents and packages.

Do **NOT** substitute other devices if the tow bar pins and clips are misplaced.

DEALER or INSTALLER:
Be certain the user receives the instruction sheets for their products.

Be sure that **ALL** electrical connections are plugged in properly and functioning **BEFORE** installing the fascia.

BX1840

2007-12 Nissan Sentra

Installation Instructions



Shown without removable tabs installed.



Shown with removable tabs installed.

If the baseplate is in an accident, it must be replaced. DO NOT use it again! An accident can cause unseen damage and using it again could result in more damage or serious injury. DO NOT use the baseplate if it is damaged or missing parts.

CUSTOMER SERVICE COMMITMENT

Blue Ox is committed to providing you with exceptional customer care throughout your lifetime with our products. Our team is here to assist you with any questions you may have regarding the performance of your product. Simply call 1-402-385-3051 and you can speak with our customer care team.

Additionally, please visit our website to see which rallies our Destination America team will be attending. For a nominal fee, our service technician will service your towing system to ensure it's in proper working condition. Also, as a commitment to our customers, should you visit our factory, you can stay at our full service Blue Ox campground at no charge along with enjoying a factory tour.

Again, thank you for being our customer and for the confidence you have shown in the performance of our products. It is because of customers like you we enjoy the success we have today.



© 2011 Blue Ox
One Mill Road, Industrial Park
Pender, Nebraska 68047
Phone: (402) 385-3051 • Fax: (402) 385-3360
www.blueox.com

General Information

1. Ensure that your product(s) are registered online at www.blueox.com. It is crucial to register your product(s) so that you may be alerted of product offerings, updates, upgrades, maintenance and safety bulletins, and/or recalls.
2. **It is the owner's responsibility to inspect all towing equipment for cracked welds, missing or worn parts and loose bolts before each towing trip.** Be sure to use Loctite® Red on all bolts and tighten to the recommended specifications.
3. **It is the owner's responsibility to hook up all towing equipment per manufacturer's instructions/recommendations.**
4. Remove the attachment tabs when not in use (if applicable).

Notice To Baseplate Installer

1. It is YOUR responsibility to watch for:

- Oil cooler and air conditioner lines
- Electrical wires and hoses
- Missing parts or attaching points on the frame

** If the baseplate is improperly installed and is against a wire or hose, it could cause fluid leaks or electrical shorts some time after the actual baseplate installation.

Permanent Baseplate Safety Cable Installation

Permanent baseplate safety cables are strongly recommended when towing a vehicle with a tow bar. The principle function of the permanent baseplate safety cables is to prevent the towed vehicle from breaking loose in the event the connection between the frame of the towed vehicle and the baseplate fails or becomes disconnected. The cables must be connected from the baseplate to the frame rail or cross member of the vehicle's frame. The illustrations below show the possible arrangements recommended by Blue Ox®. Each permanent baseplate safety cable must have an adequate weight rating for the towing system. The weight rating of the two (2) cables together will not qualify.

Do not mount the permanent baseplate safety cables against wires, hoses or brake lines.

These permanent baseplate safety cables should remain installed as long as the baseplate is installed on the vehicle. Permanent baseplate safety cables are to be used in conjunction with, and NOT a replacement for legally required safety cables attaching the towed vehicle to the towing vehicle.

OPTION #1

Permanent Baseplate Safety Cables to Cross Member or Frame of Towed Vehicle.

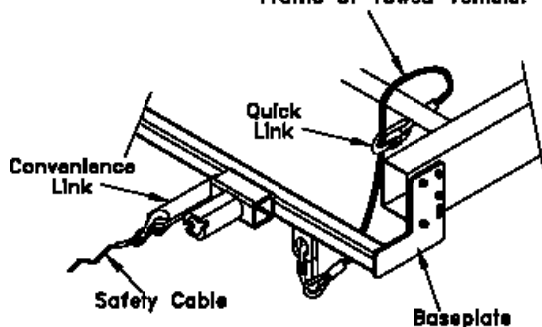

OPTION #2

Permanent Baseplate Safety Cables to Cross Member or Frame of Towed Vehicle.

